

**INFLUENCE OF MORAL INTENSITY, ETHICS CULTURAL
AND PROFESSIONAL IDENTITY ON INTENTION OF
WHISTLEBLOWING ACTION**

SYAMSU ALAM

*Accounting Department,
Indonesian Muslim University, Makassar*

ABSTRACT

This research was intended to examine about: the influence of moral intensity, ethics cultural and professional identity, simultaneously and partially, on intention of whistleblowing action of teaching accountant; the influence of moral intensity, ethics cultural, professional identity and intention of whistleblowing action simultaneously and partially on academic fraud of teaching accountant in KopertisIXth Region Sulawesi. The study was conducted by the survey method. The number of respondents was 174 respondents' lecturers (teaching accountant) from 27 PTS in Kopertis IXth Region Sulawesi. The data used in this research were primary data collected by questioners. The validity and reliability of the data were tested before hypothesis testing. The analysis method used throughout this research was descriptive analysis further with structural equation modeling (SEM) in Software Program Lisrel 8.70. The results obtained on the following research includes: 1). There is a positive influence of moral intensity, ethics cultural and professional identity simultaneously and partially on intention of whistleblowing action of teaching accountant; 2). The influence of moral intensity, ethics culture, professional identity and intention of

whistleblowing action simultaneously and partially on academic fraud of teaching accountant are negative significant in Kopertis IXth Region Sulawesi.

Keywords: Moral intensity, ethics culture, professional identity, academic fraud.

BACKGROUND INFORMATION

The need for professional accountants to rise across sector lines along with the increasing demands for public accountability and the establishment of organizational governance. Insufficient number of employees who have the capability and integrity that are responsible for performing accounting and financial reporting process has been a challenge for the institution to provide professionals who have such integrity. Currently, at least Indonesia needs about 46,000 staff accountant as state fiscal managers in both the central and regional levels. Availability of accountant educators, who have the character and integrity, is a pivotal figure in the process of knowledge transfer. It can be said that the quality of graduates of Accounting Studies Program is determined by the personality of accountant educators. However, the

Accounting Studies Program in its management still cannot meet the ideal standards of the various aspects that will certainly have an effect on the dimensions of knowledge, skills and experience that should be owned as accountant professional educators. The lack of appreciation in the publication of scientific papers, which resulted in the lack of development of academic skills practiced, so it is conditioned on several accountants-educators rarely

perform tasks such scholarly research activities and community service even never at all. The case of the takeover of the scientific work of others (plagiarism) showed low dedication as an accountant educator.

Evaluation of curriculum in Accounting Studies has not been revised periodically, so as not demonstrative as an instrument of control to monitor the accountant educators in performing academic tasks. It can be a stimulus for certain parties commit unethical acts, so the opportunity of academic fraud. An overview of these limitations reflects lack of qualified accountants educators as a change agent in society. If not accompanied by an adequate understanding of ethical culture and the identity of the profession is good, and then the condition is certainly very vulnerable to fraud and hurt many parties. According to Eckstein, (2003) activities which include categories unethical or academic violation is forbidden include 1) cheating in examinations; 2) plagiarism; 3) jockey; 4) counterfeiting; 5) bribery; 6) discriminatory actions, and others. Academic fraud by accountant educators modus operandi is absent from his scholastic duties. Accounting educators are teaching not in accordance with the syllabus lasted so long at several Universities. Culture of exam supervision is not performing well. To prevent this unethical, it takes the attitude of the accountants-educators themselves in educational environments. Characters uphold the principles to be normative, integrity and courage to take risks (whistleblowing actions) become very important although it is rarely seen.

Fraud is a moral offense, so it is a moral responsibility for everyone to keep it. Besides the educational process is a process of acculturation. If it has been a cultural phenomenon in society, the

ethical responsibility of the national education to improve national education in the prevention of academic fraud (Djalal, 2001). Fraud will cause much harm to the institution, both the tangible assets and intangible assets of the institution. It is an undeniable fact that some universities indicated to practice unhealthy (red flags). This phenomenon is so common and allegedly the motive is looking for profit opportunities. Higher education is viewed as a revenue center that serves as the wealth creating institution.

Accounting Study Program is expected to produce graduates (undergraduate accounting), are knowledgeable and have the technical ability and professional ethics should be able to prevent academic fraud. Correspondingly, Wijatno, (2009), said that it is necessary to explain how the moral ethics that apply specifically in the various academic activities, including in this case the Accounting Studies Program to prevent dysfunctional behavior (fraud) of course by building a moral intensity and good culture ethics. In addition intensity, moral, culture of ethics and professional identity, academic fraud prevention cannot be separated from the attitude of the character of the accountant's educators as a whistleblower. They take risks with all the logical consequences to be borne on his gesture. Whistleblowing actions will give good control effect for criminals to always introspective and stop of even the fraudulent action.

FORMULATION OF THE PROBLEM

Based on the description of the background, study formulated some key issues that need in depth study as follows:

1. Does the intensity of moral, ethics cultural and professional identity of educator accountant affect the intention of whistleblowing action accountants in environmental educators Kopertis Region IX Sulawesi?
2. Does the intensity of moral, ethics culture, professional identity and intention of whistleblowing action accountant educator's effect on academic fraud accountant educators in environmental Kopertis Region IX Sulawesi?

SCOPE OF RESEARCH

This study will add to their knowledge, especially personality development whistle blow accountant educators to prevent academic fraud. The results of this study will provide contributions to the sustainable development of accounting education by integrating the concept of moral intensity, cultural ethics, professional identity, whistleblowing actions that can be teaching materials (enrichment) in accounting sciences in particular to prevent fraud in general. The results of this study as a reference for subsequent researchers who pursue the field of accounting education.

THEORY AND HYPOTHESES

The Attribution Theory

The theory developed by Heider is studying the process for how people interpret things the events, reasons, or because his behavior. A person's behavior is the byproduct of a combination of internal and external forces. In making that judgment on others,

human perception will be associated with the attribution theory. The same was stated by Robbins (2003) indicates that the attribution theory is the explanation of the ways people judge people differently, depending on the meaning of what is linked to a specific behavior. Basically, this theory suggests that if one observes the behavior of an individual, the person is just trying to determine whether the behavior was caused by internal or external factors. The behavior of someone in the organization as an act of whistleblowing cannot be separated from this theory. Actions or decisions taken by the accountant educators that to expose the evil cause are attributable to some causes. Factors such as holding fast to the principled ethics and professional attributes are the factors that cause whistleblowing actions. These actions are taken to avoid such crimes.

LITERATURE REVIEW

Moral Studies, Ethics and Professionalism

Moral and Ethics

Cheating is an illegal action. It is a part of unethical behavior. Consequently laws must be enforced as a part of enforcement efforts in ensuring ethical standards. Several studies in the field of ethics have used the theory of moral development in order to observe an individual basis to perform an action. One major theory that which is often used is the 'theory on the level of moral reasoning of Kohlberg. Welton et al. (1994) stated that individual ability to resolve ethical dilemmas are influenced by the level of moral reasoning. In this context Kreshasturi (2014) stated moral intensity is a construct that includes the characteristics associated

with a major moral issue in a situation that will affect the individual's perception of ethical issues and behavioral intentions he had. Jones (1991) also reports that a person's ethical behavior may depend on decisions which are taken at the moral level. Alvarez (2010) examined the effect of the intensity of the moral dilemmas and ethical judgment on the intention to behave ethically. The results show that the intensity of the moral dilemmas' significantly influences the intention to behave ethically. Results from several studies (presented in Liyanarachi2009) showed that the level of individual moral reasoning will affect their ethical behavior. According Rest and Narvaez (1994) (in Liyanarachi2009), higher the person's level of moral reasoning, higher would be likely to do the right thing.

Moral and Professionalism

Profession and professionalism can be distinguished conceptually. Profession is the kind of work that meets some criteria, while professionalism is an essential attribute individually without seeing a work is a profession or not (Lekatompessy 2003 in Herawati & Susanto, 2009). Simply put, professionalism means that the auditor shall perform his duties with seriousness and rigor. As a professional, the auditor should avoid negligence and dishonesty. Maali (2010) mentioned that professionalism is a form of individual responsibility to behave better than simply complying with laws and regulations of existing society. It is generally perceived that a person is said to be a professional if he/she meets the three criteria, which include; a) of having the expertise to carry out duties in accordance with the field, b) carrying out a task or profession by setting clear standards in the

professional field concerned and c) stints profession in compliance with the established Professional Ethics.

Culture Ethics and Professionalism

In an academic culture, educators understand how to behave towards his profession, adapt to coworkers, the work environment and apply reactive to policy direction, forming a system of values, habits, carrying the image of the academic ethos of work. It should be internalized in his/her life so as to encourage better appreciation from the organization and deliver better job performance. This ethos of work is either formed by the organization itself or by academic leaders who issue an ethical policy that needs to be acceptable, when one enters the organization. Academic culture can be obtained through the process of transformation when academic institutions march towards ideal academic culture. Understanding a culture is accompanying with the lecturer's personality and attitude in addressing the job professionally, where the academic culture can be perceived as the deeply held values, which are widely shared as members of the academic community. Culture facilitates the formation of individual personality integrating people into the organization values more widely. Schein, (1992) defined culture as "a pattern of shared basic assumption that the group learner as it solved its problems of external adaptation your internal integration, that has worked well enough to be considered invalid and therefore, to be taught to new members as the correct way to perceive, think and feel in relation to reviews these problems".

Learning environment itself supports the imagery across the organization, so it can be viewed as a culture, will affect the

reciprocation of an organization. A strong professional character and its culture will improve organizational performance and simultaneously improve self-image. The influence of culture on the performance of a teacher can be seen from a culture of achievement (a form of professionalism) a lecturer in the role, which (Handi, 1985) is the respective culture.

In order to improve the scholarly culture and professionalism, lot of steps to be taken by the lecturer (Sufyarma, 2004). This includes:

- Improving the quality of faculty commitment to the development of science in line with the task of education and community service.
- Fostering academic culture that is conducive to improve intellectual activity.
- Pursue further education and other development programs in accordance with the priorities of the program of study.
- Rearrange the placement of lecturers in accordance with its domain expertise so that professionalism and efficiency can be improved.
- Update the knowledge of lecturers constantly and continuously.
- Whistleblowing Actions, etc.

Moral Intensity to the Intention does Whistleblowing

Perception of control behavior is a person's belief that perception is the result of self-control on the perceptions of the behavior (Kreshastuti, 2014). Hendriadi (2012) defines a moral intensity as the strength of the hard feelings or happy as a result of an act is good or bad, right or wrong, fair or unfair. Moral intensity is

given the opportunity to affect the intention of the auditor to report violations. Graham (1986) in Taylor and Curtis (2010) indicates that the purpose of the report offenses of others is a fusion between the seriousness of the offense and the responsibility felt towards action report violations. Shawver (2011) conducted a study to test the effect of moral intensity on the intention of reporting. Someone reported violations because they feel responsible for the report. The results support the research Lai (2011), which looks into the relationship between moral intensity to the action report violations. The results show that the moral intensity influences whistleblowing actions.

Ethical Culture in Action Whistleblowing Intentions

Cultural values that constitute a system into the basic assumptions of an organization engaged in improving a performance. A strong culture has the key aspects of functioning of the organization in terms of efficiency, innovation, quality and support proper reaction to accustom the events, because the prevailing ethos accommodates resistance (McKenna, et al, translation Toto Budi Santoso, 2002). Strong culture can also serve as a culture that held intensive, widely embraced and more clearly disseminated and passed on and affect the environment and human behavior (Ndraha, 2003). Culture is the values, concepts, habits, and feelings which are taken from the basic assumption of an organization, further is internalized by its members. It can be a direct behavior in case of problems or it is in the form of a distinctive character, which is an image that supports an academic sense of pride in teacher's profession as a lecturer, develop a feeling of belongingness and participate in implementing all policies, leading to a the pattern of communication with internal and

external environment of learning. Harrison in McKenna (2002) says this culture is more focused on a number of leaders using more power in the way of governing. Cultural power is also under an obligation to follow the requirements especially being member of an organization. An integrated effort from a professor, teacher and employees' set the command and policies, jotting down rules of the firm.

Professional identity of the intentional act whistleblowing

Aranya, et al., (1981) defines a professional identity as a person's strength to its involvement in a profession. One of the ways in which individuals demonstrate professional identity is through compliance with the standards and practices of their profession. Jeffrey and Weatherholt (1996) in Taylor and Curtis (2010) found that professional accountants commitment is positively associated with the observance of the rules attitudes, such as professional training, standards and codes of conduct. One of attitude an auditor to show professional identity is through compliance with auditing standards and code of professional conduct set out in the auditor Public Accountants Professional Standards and Code of Professional Ethics for Certified Public Accountants. Jeffrey and Weatherholt (1996) examined the relationship between professional commitments, understanding of ethics, and the attitude of obedience to the rules, indicates that accountants have a strong professional commitment behavior is more directed at the observance of rules compared to professional accountants who have committed low. Kaplan and Whitecotton (2001) in Taylor and Curtis (2010) found that a positive professional identity associated with the obligation to report the unethical behavior of others that ultimately affect the intention to report. Further

research conducted by Smith and Hall (2008) in Ghani (2010) found that the auditor's professional identity will affect his opinion about the importance of reporting suspicious actions. It was concluded that the auditors have a strong professional identity tend to report violations of the organization both as a means to protect their own profession or eradicate violations in the public interest.

Fraud Prevention

The Intensity of Morality to Fraud

Wilopo (2006) found that a higher level of moral reasoning that people will be more likely to not do the accounting fraud. Morality management provides a significant negative influence on the tendency of accounting fraud. This means that the higher the morality, less likely the trend of accounting fraud. According Koletar (2003), abuse of office is a behavior/moral is not in accordance with the guidelines or rules applicable, both written and unwritten, and their habit of gambling is a factor affecting the level of cheating someone. Wilopo (2006) states that morality management provides a significant negative influence on the accounting fraud. This means that the higher morality of management accounting fraud or the higher the stages of moral management, more management attention are in need rather merely work on the interests of enterprises, especially for private interests. Fauwzi (2011) states morality significantly and negatively related to accounting fraud. A factor driving someone to commit fraud is caused by moral factor viz., greed (greed). Everyone has the potential to behave greedy because in general

the nature of human being had never felt satisfied. So cheating arises because of the greed in a person.

Effect of Ethical Culture to Fraud Prevention

According to Pertiwi (2010), ethical behavior is a behavioral assessment of the professionalism of an internal auditor in preventing and detecting fraud related aspects of behavior. In research conducted by Rae and Subramaniam (2008) (in Pramudita2013) showed that in an environment that is more ethical, an employee will be more likely to perform the rules of the company, and try to avoid acts of fraud within the agency. The environmental ethic can be assessed by the ethical culture of the organization. According to Tepeci (2001) in Savitri (2011), organizational culture is a common perception held by members of the organization, a system and a shared meaning. Culture includes the norms and values that guide the behavior of members of the organization. Organizational Culture significantly contributes to the formation of virtuous behavior, because the organizational culture is a set of values and norms that guide the actions of employees. Culture can encourage the creation of ethical behavior, and vice versa can also encourage the creation of dishonorable behavior. With the organization's ethical culture that affects every member of the organization to comply with accepted business ethics. Here the internal control can be run without significant barriers because the system cannot run without human intervention therein. Kusumastuti (2012) and Pramudita (2013) examined the return on the effect of ethical culture of the organization and effectiveness of internal controls on the tendency to overcome accounting fraud at Jembrana District Government. Culture of the organization and effectiveness of internal controls

acts as independent variables and the tendency towards accounting fraud is acting as the dependent variable.

Effect of Professionalism to Prevent Cheating

According to Yunintasari (2010), in order to prevent fraud, requires professional performance. Internal auditor's tendency to engage in fraud may not be prevented if the internal auditor did not perform their role and responsibilities in a professional manner. The researcher concluded in this context that the professionalism of an auditor is required in detecting a fraud. The higher the professionalism of an auditor, there are more the quality audit results. With the attitude of professionalism, an auditor is in a position to detect and prevent fraud. Professionalism of an auditor can be observed in the results of the audit he was doing. Auditors are professionals working indiscriminately. On whomever, he finds any fraud, he will reveal the fraud.

Whistleblowing System to Fraud Preventions

According to the National Committee, on Governance (2008) one of the benefits of the implementation of whistleblowing system is the emergence of reluctance to commit the offense, extending confidence in the effective reporting system. The existence of the whistleblowing system not only acts as a channel for reporting fraud occurring, but also as a form of supervision. Employees become afraid to commit fraud because this system can be used by all employees, so that fellow workers became mutual monitoring of each other and are afraid to report another employee for committing fraud. Understanding of whistleblowing mechanism

will make employees to become enthusiastic in reporting any fraud to the relevant authorities who are dealing with the report because the whistleblowing system already includes whistleblower protection. This can help prevent fraud in the company. Widyantari (2013) states that the effectiveness of whistleblowing systems helps companies get out of fraud occurring within the company and helps the company to achieve the preplanned goals in a clean way. Priantara (2013) states that one of the systems used to prevent fraud is to implement a system for reporting allegations of fraud (Whistleblower hotlines).Based on the theoretical description above, the relationship between variables in this study can be described as follows:

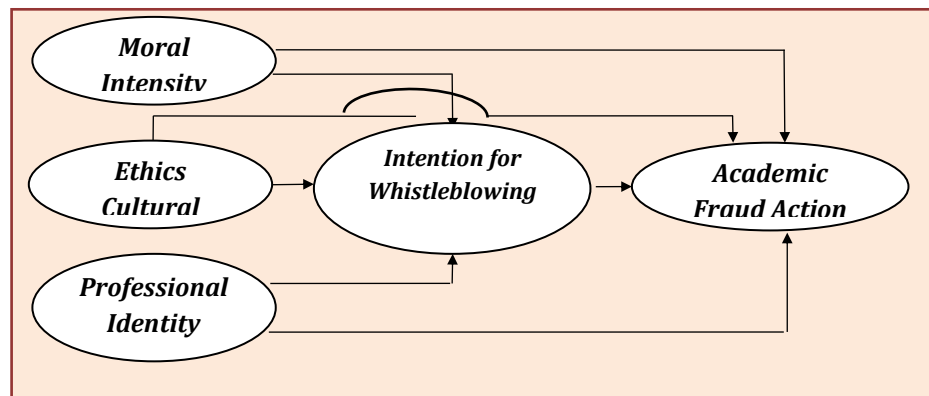

Figure 1.
Research Paradigm

Hypothesis

Based on the research framework can be proposed research hypotheses as follows:

1. Moral intensity, ethics and professional cultural identity have significant direct and positive influence on whistleblowing intention

and action either simultaneously or partially in the Kopertis Region IX Sulawesi.

2. Moral intensity, ethics and professional cultural identity have significant direct and positive influence on whistleblowing intention and action on academic fraud among accountant educators in the Kopertis Region IX Sulawesi.

RESEARCH METHODOLOGY

The variables selected for the study include moral intensity, cultural ethics, professional identity, intention of whistleblowing and academic fraud. This study followed confirmatory factor analysis to evaluate patterns of interrelationships between multiple constructs. The unit of analysis includes the accountant educator in the Kopertis Region IX Sulawesi, to clarify the hypothesis formulated, the variables identified and that need to be operationalized. The classification of the variables is as follows:

Variable Exogenous (ξ), as follows:

- Moral intensity (ξ_1)
- Ethics cultural (ξ_2)
- Professional identity (ξ_3)

Variable Endogenous (η), as follows:

- Intention of whistleblowing action (η_1)
- Academic fraud (η_2)

In this study, a population or universe is the entire accounting educators as much as 324 accounting lecturers. The sampling technique used was Simple Proportional Random Sampling by the formula:

$$\text{Proportion} = \frac{\sum \text{teaching accountant in an institutio n}}{\text{Total teaching accountant in Kopertis IX}} \times \text{Respondent s intended}$$

Determination of minimum number of respondents is done by using the formula of Taro Yamane quoted from Rakhmad (1998) as follows:

$$n = \frac{N}{N \cdot d^2 + 1}$$

Information:

- n = sample size
- N = population size
- d2 = precision specified that 5 % (0.05)
- 1 = number constants

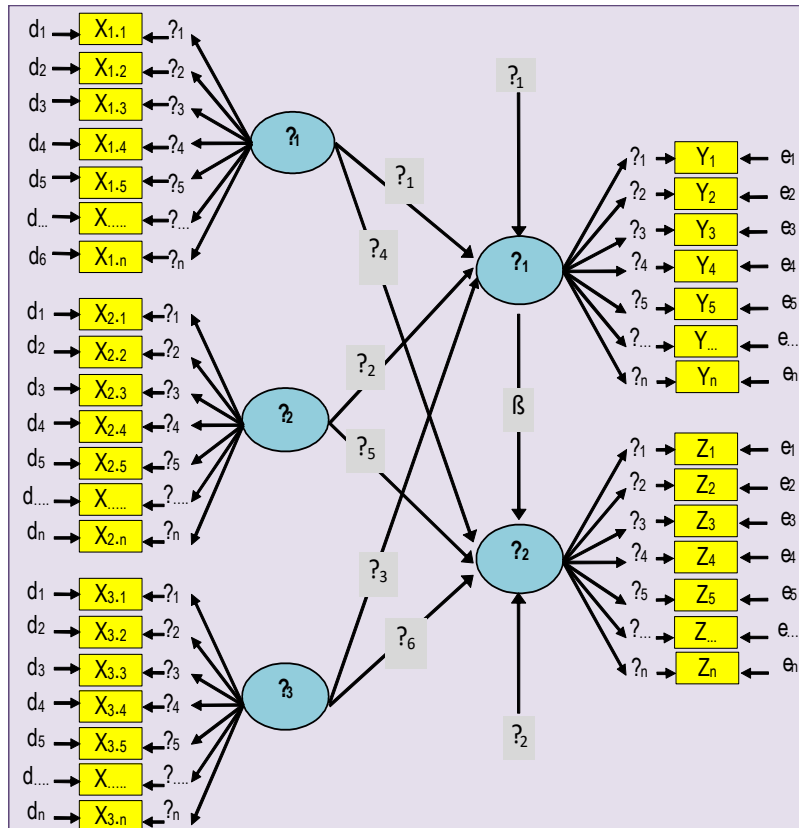

Figure 2.
 Diagram Line and Measurement Model

A total of 324 accounting lecturers were allocated into the 27 Study Program of Accounting. Nevertheless, 174 accounting lecturers as respondents is considered as the unit of analysis in this study. The analytical method used in

this research is the Structural Equation Modeling (SEM). Selection analysis technique is based on the considerations that structural equation models have the capability for simultaneous testing and it is efficient when compared to other multi-variate techniques (Hair et. al. 1988). Based on the model of the theoretical framework that has been built is transformed into the shape of the path diagram (path diagram) to describe the causality of constructs to be used. In this study, there are three variables / constructs exogenous (Intensity Moral, Ethics and Professional Cultural Identity) and two variables / constructs endogenous (Intention of Whistleblowing Action and Academic Fraud).

Full Display path diagram shown in Figure 2. Based on the concept of the research model the mathematical form can be formulated as follows:

Table 1
 Equation measurement model "Exogenous Variables":

Exogenous Indicator	Exogenous Constructs			Error
	ξ_1	ξ_2	ξ_3	
X1	= $\lambda \xi_1$	+ δ		
X2	= $\lambda \xi_2$	+ δ		
X3	= $\lambda \xi_3$	+ δ		

- ξ_1 Moral intensity ξ_2 Ethics cultural ξ_3 Professional identity

Table 2
 B Equation measurement model "Endogenous Variables":

Exogenous Indicator	Exogenous Constructs			Error
	η_1	η_2		
Y	= $\lambda \eta_1$	+ ϵ		
Z	= $\lambda \eta_2$	+ ϵ		

η_1 Intention of whistleblowing action η_2 Academic fraud

The primary data and secondary data, techniques used in this study as follows: 1) questionnaires; 2) Study Library; 3) Field Study (Field Research); 4) Study Documentation; 4) In-depth interviews (in-depth interviews). To test the above hypothesis t test was used, so that the level of alpha = 5 % reject H0 if t-value > t-table and accept H1 if t-value < t-table. Testing the hypothesis empirically was done by using Structural Equation Modelling (SEM) Lisrel software Version 8.70.

RESULTS AND DISCUSSION

There are two sub structures to be tested in this study. Prior to test the effect on the two substructures, first described structural equation model to five variables studied

Table 3
Relations Between Latent Variable Structure Model

Exogenous Constructs	Exogenous Constructs				Error
	ξ_1	ξ_2	ξ_3	η_1	
η_1	$\gamma_1 \xi_1$	$\gamma_2 \xi_2$	$\gamma_3 \xi_3$	-	+ ζ
η_2	$\gamma_1 \xi_1$	$\gamma_2 \xi_2$	$\gamma_3 \xi_3$	$\beta_1 \eta_1$	+ ζ

From the results of data processing using software LISREL structural equation as follows:

Table 4
 The Processing Results of Relations Between Latent Variables Structure Model

Exogenous Constructs	Exogenous Constructs				Error
	ξ_1	ξ_2	ξ_3	η_1	
η_1	0,316	0,271	0,376	-	+ 0,430
η_2	-0,147	-0,188	-0,368	-0,339	+ 0,277

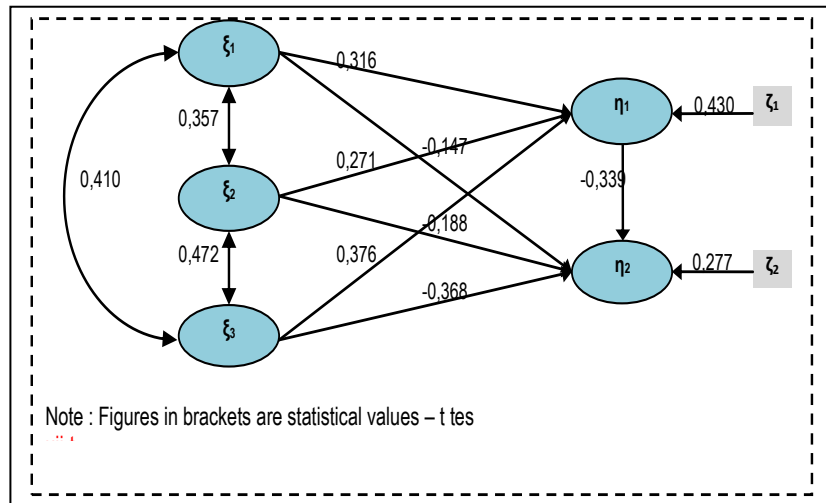

Figure 3.
 Line Structural Relationship between Latent Variables

Table 5
 Criteria Goodness -of -fit Indices: Structural Testing between Latent Variables

Criteria	Value of Cut-off	Computational results	Information
Chi-Square	Expected smaller Acceptable Chi-Square < 2 df	4508.79	Acceptable
Probability significance	> 0,05	0.000	Acceptable
RMSEA	< 0.05	0.048	Good
CFI	> 0.90	0.968	Good
NNFI	> 0.90	0.967	Good

The calculation of Goodness-of-Fit Indices for the model obtained χ^2 value of 4508.79 with a p-value = 0.000. The results indicate that a significant χ^2 test ($p < 0.05$). When viewed by the criteria of Chi-Square, the model obtained do not meet the ideal criteria where the expected value of χ^2 small (not significant) with a p-value > 0.05 . But the value χ^2 obtained (4508.79) is still acceptable for less than two degrees of freedom ($2 \times 3229 = 6458$). RMSEA value indicates Goodness of Fit that can be expected when the model is estimated in the population. RMSEA value ≤ 0.05 shows the model fit to the data (based on the number of degrees of freedom (degrees of freedom) in the model. Value RMSEA (Root Mean Square Error of Approximation) models obtained at 0.048. It can be said that the model is obtained by the value of RMSEA = 0.048 has a degree of fit (fit) with data. Another comparative size is to use non-normed Fit Index (NNFI) and Comparative Fit Index (CFI). Non-normed Fit Index (NNFI) models obtained is 0.967, and Comparative Fit Index (CFI) is 0.968, model that is obtained. It appears that all the criteria used to assess a model have good values therefore acceptable models. Thus the model proposed in Figure 3. A final structural model, between latent variables will be used in further analysis.

Effect of Simultaneous and inter Partial Variables Studied

Hypothesis testing is done by : 1) tested the hypothesis that the intensity of moral, cultural and professional ethics identity positive influence on the intention of whistleblowing action either simultaneously or partially ; 2) test the two hypotheses were formulated that moral intensity, cultural ethics, professional identity and intention of whistleblowing action positively affects the academic fraud either simultaneously or partially in the Kopertis Region IX Sulawesi , appears as in Table 6 and Table 7.

Table 6
Direct and indirect effect

Variable	Coefficient Path	Influence Directly	Indirect Influence	Total
ξ_1	0,316	10,0%	7,9%	17,9%
ξ_2	0,271	7,3%	7,9%	15,2%
ξ_3	0,376	14,2%	9,7%	23,9%
Total Effect simultaneously				57,0s%

Together moral intensity, cultural ethics and professional identity able to explain the changes in the intention of whistleblowing action amounted to 57.0 % and the balance of 43.0 % is explained by other factors which are not examined.

Table 7
Direct and indirect effect on Academic Fraud

Variable	Coefficient Path	Influence Directly	Indirect Influence	Total
ξ1	-0.147	2.2%	6.0%	8.2%
ξ2	-0.188	3.5%	7.8%	11.4%
ξ3	-0.368	13.5%	13.4%	26.9%
η1	-0.339	11.5%	14.3%	25.8%
Total Effect simultaneously				72.3%

Collectively moral intensity, cultural ethics, professional identity and intention of whistleblowing action was able to explain the changes in the Academic Fraud of 72.3% and the remaining 27.7% is explained by other factors which are not examined.

This study shows that the level of intention of whistleblowing action in PTS is very low and does not exert strong influence in preventing the occurrence of academic fraud. The concept of whistleblowing intention of action is not fully understood by the service providers in the execution of their duties as educators. The strategic role of the institutions to define clearly the concept of intention of whistleblowing action and provide understanding and create conditions so that each element of the academic community as service providers clearly understand the concept of intention of whistleblowing action and strive to achieve accountability in academic service delivery.

Table 8
Summary Significance inter Variable Effect

Variable		Coefficient Influence	t-value	t-critical	Conclusion
Moral Intensity	Intention of Whistle-blowing Action	0.316	4.647	1.96	significant positive effect
Ethics Cultural	Intention of Whistle-blowing	0.271	3.955	1.96	significant positive effect
Professional Identity	Intention of Whistle-blowing	0.376	5.075	1.96	significant positive effect
Moral Intensity	Academic Fraud	-0.147	-2.286	1.96	significant negative effect
Ethics Cultural	Academic Fraud	-0.188	-2.889	1.96	significant negative effect
Professional Identity	Academic Fraud	-0.368	-4.818	1.96	significant negative effect
Intention of Whistle-blowing	Academic Fraud	-0.339	-3.851	1.96	significant negative effect

Fraud has become the menace of the modern business world that has been shown to have destroyed both public and private organizations. The threat of fraud is of course also haunting educational arena in Indonesia. Fraud within a specified period would destroy its financial capability and lost the confidence of investors and creditors. It will ultimately raise the cost of capital for high risk. The perpetrators of fraud can be comprised of staff level employees to top executives of an organization.

CONCLUSION

Referring to hypothesis testing, analysis and discussion of the results and findings of the research results, it can put forward some conclusions empirically as follows:

1. Moral intensity, cultural and professional ethics identity affects the intention of whistleblowing action. This indicates that high moral intensity by accepting cultural ethics and professional identity will support the intention of whistleblowing action among accountants and educators Kopertis Region IX Sulawesi.
2. Moral intensity accountant educators influence the intention of whistleblowing action of accountant's educators. This indicates that high moral intensity of accountant educators will increase the intention of whistleblowing action.
3. Cultural ethics influence performance accountability of accountant educators, synonymous by accepting cultural ethics, will be to improve the implementation of performance accountability accountant educators.
4. Professional identity of accountants and performance accountability influences the educators. It does mean that the process of effective management control, will improve accountability in the academic environment of Kopertis Region IX Sulawesi.
5. Moral Intensity of accountant educators, ethical culture, professional identity and intention of whistleblowing action influences the academic fraud. This indicates that high moral strength of accountant educators, accepting cultural ethics, professional identity and intention of

whistleblowing action can prevent academic fraud in the Kopertis Region IX Sulawesi.

6. Moral intensity of accountant educator's influences the academic fraud. This indicates that high moral strength of accountant educators, prevent academic fraud.
7. Superior understanding of cultural ethics will prevent academic fraud.
8. Skilled identity fraud affects the academic professionals. An educational institution with a moral identity will be able to prevent academic fraud in the Kopertis Region IX Sulawesi.
9. Intention of whistleblowing action of the Accounting Educators effect on scholarly fraud, meaning that with the realization of the intention of whistleblowing action educator high accountants will prevent academic fraud in the Kopertis Region IX Sulawesi.
10. Non achievement of the intention of whistleblowing action to the fullest and inadequate control mechanisms leads to the potential for the occurrence of academic fraud, especially in the academic service users.

SUGGESTIONS

This research, which is in the areas of accounting, supposed to be the base for more specific research in financial accounting, management accounting, taxation and accounting fields (family) other accounting. For the development of science, especially in the areas of accounting, this research is supposed to be a reference for similar studies in different contexts such as research on non-governmental organizations that are non-profit.

REFERENCES

- Aditya, P. (2013). Analysis of Fraud in Government Sector Salatiga. *Accounting Analysis Journal* 1(3).
- Aranya, et al, (1981).Community Size, Socialization, and the Work Needs of Professionals, *Academy of Management Journal*.
- Aranya, N., &Lachman , R. (1998). Evaluation of Alternative Models of Commitments and Job Attitudes of Professionals. *Journal of Occupational Behavior*, 7.
- Arti, W. (2013). *Influence of Effectiveness of Disclosure System Whistleblowing Efforts against Cheating Management through Giving Motivation (a case study in Cirebon City Department of Education)*, Universitas Pasundan.
- Fauwzi, (2011).Analysis of Influence the Effectiveness of Internal Control, Compliance Perception Compensation, Morality Management to Unethical Behavior and Accounting Fraud Trends. *Jurnal Akuntansi Universitas Diponegoro Semarang*.
- Handy, (1985). *Understanding Organizations*, (London: Penguin,) in Eugene McKenna and NicBee, *The Essence of Human Resource Management*, translation Toto Budi Santoso, (Yogyakarta : Penerbit Andi, 2002)
- Hendriadi.,&Firmansyah, (2012). *Effect of Intensity Moral, Risk Awareness and Moral considerations to Buying Decision of Software Pirated Windows 7 on Students in Surabaya, STIE Perbanas, Surabaya*.<http://www.bappenas.go.id/print/27/semnas-peran-sistem-whistle-blowingdalam-pandangan-ternal-auditor-pemerintah/> (accessed on 5th October 2015)
- Jeffrey, C., &Weatherholt, N. (1996). Ethical Development, Professional Commitment, and Rule Observance Attitudes: A Study of CPAs and Corporate Accountants. *Behavioral Research in Accounting*, 8, 8-31.

- Jones, D. (1991). A novel approach to business ethics training: Improving moral reasoning in just a few weeks. *Journal of Business Ethics, 88*, 367-279.
- Joseph. K. W. (2003). *Fraud Exposed*. New York: John Wiley and Sons, Inc.
- Kaplan, S., & S.M. Whitecotton. (2001). An Examination of Auditor's Reporting Intentions when Another Auditor is offered Client Employment. *Auditing: A Journal of Practice & Theory, 20*(1).
- Kreshastuti, D. K. (2014). Analysis of Factors Affecting Intention to Take Action Auditor Whistleblowing. *Diponegoro Journal of Accounting, 3*(2), 1-15.
- Liyanarachi, G., & C. Newdick. (2009). The Impact of Moral Reasoning and Retaliation on Whistle-Blowing: New-Zealand Evidence. *Journal of Business Ethics*.
- Maali, B., & Napier, C. (2010). Accounting, religion and organizational culture: the creation of Jordan Islamic Bank. *Journal of Islamic Accounting and Business Research, 1*.
- McKenna., Eugene., & Beec, N. (2002). *The Essence of Human Resource Management*, translation Toto Budi Santoso, (Yogyakarta :Penerbit Andi)
- Putri.P.E. (2010). *Analysis of Effect Component Internal Auditor Skills to Fraud Detection and Prevention (Fraud) in the Inspectorate General of the Ministry of Commerce of the Republic of Indonesia*, Universitas Islam Negeri Syarif Hidayatullah Jakarta.
- Rahardian G.M. (2010). *Analysis of Difference Professional Commitment and Socialization Anticipatory Student Non - PPA and PPA in Conjunction with Whistleblowing*, Universitas Diponegoro.
- Robins, S.P. (2003). *Organizational Behaviour* Edn 10th Edition. Prentice Hall Pearson Educational International, PT Ideks. Jakarta: Gramedia.

- Safitri, Y.H. (2010). Effect of Independence and Internal Auditor Professionalism In Effort to Prevent and Detect Fraud Occurrence. Jakarta. FE, Universitas Negeri Islam Syarif Hidayatullah
- Sawitri,&Peni. (2011). Interaction the Organizational Culture and Management Control Systems to Industrial Manufacturing and Services Performance Business Unit. *Journal of Management and Entrepreneurship*, 13(2).
- Smith, R., Tiras, S., &Vichitlekarn, S. (1997).*The Interaction between Internal Control Assessment and Substantive Testing in Audits for Fraud*. Working Paper www.ssrn.com (accessed on 5th September 2015)
- Sufyarma, (2004). Capita-selecta: Educational Management, (Bandung: Alfabeta,), P.183.
- Tara, S. (2011). The Effects of Moral Intensity on Whistleblowing Behaviour Accounting Professional, *Journal of Forensic and Investigate Accounting*, 3(2).
- Taylor, E.Z., & Curtis, M.B. (2010). An Examination of the Layers Workplace Influence In Ethical Judgement: Whistleblowing Likelihood and Perseverance in Public Accounting, *Journal of Business Ethics*, 93, 21-37.
- Tsung L.C., & Chen, C.P. (2011). Moral Intensity and Organizational Commitment: Effects on Whistleblowing Intention and Behavior, *European Business Ethics Network Ireland Research Conference*, June 8-10.
- Welton, R. E., Davis, J. R., &LaGroune, M. (1994). Promoting the Moral Development Of Accounting Graduate Students. *Accounting Education.International Journal*.
- Wilopo, R. (2008). Effect of Internal Control Government Bureaucracy and the Unethical Bureaucratic Actors to Accounting Fraud in Government: Perceptions of Auditors in BPK. *Journal Ventura*, Mei.